

# LL15.70

**PORTATA MAX 230 KG**  
(2 persone 80x2=160 kg +attrezzatura 70 kg)

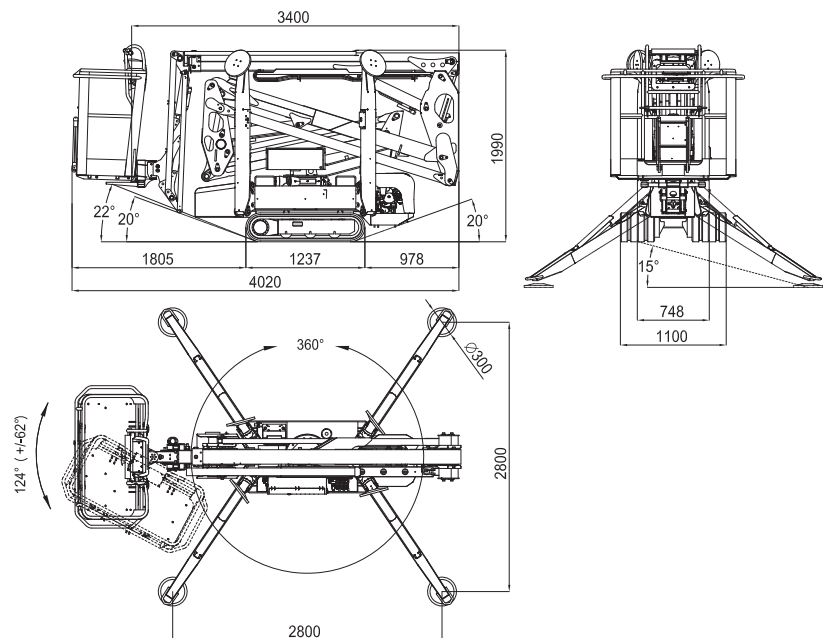

15,40 m

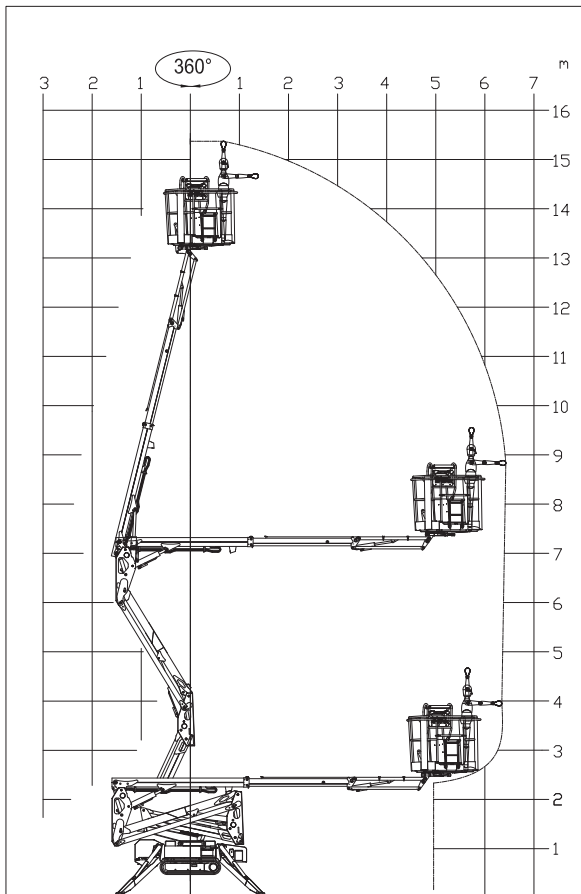

6,60 m



4,02 m



3,40 m



1,99 m



1.335 x 690 x h. 1.100 mm



124° (+/-62°)



16° / 28,7%



748 - 1.100 mm



1.670 daN - 2,36 daN/cm<sup>2</sup>



2.800 x 2.800 mm



Stabiliz. e destabiliz. automatica IIIIS di serie



Filocomando



GPRS-GPS



R.A.H.M.



Pacco batterie al litio  
3,6 kWh  
Opzionale



#### MOTORE BENZINA

Marca ..... HONDA  
 Tipo ..... GX390  
 Cilindri e cilindrata .... monocilindrico  
 ..... 389 cm<sup>3</sup>  
 Potenza lorda max .....  
 11,7HP - 8,7 kW @ 3600 rpm (GX390)  
 Avviamento elettrico ..... 12 volt

#### MOTORE DIESEL

Marca ..... HATZ  
 Tipo ..... 1B40 - HD Autorev  
 Cilindri e cilindrata .... monocilindrico  
 ..... 462 cm<sup>3</sup>  
 Potenza lorda max .....  
 ..... 10 HP - 7,5 kW @ 3600 rpm  
 Avviamento elettrico ..... 12 volt

#### SISTEMA LITHIUM-ION

Pacco batterie al litio ..... 3,6 kWh  
 Caricabatterie a bordo .....  
 ..... 220V 50Hz o 110V 50Hz  
 Autonomia di lavoro ..... 4-5 h  
 Tempo di ricarica a batterie completamente  
 scariche ..... 4 h (indicativo)  
 Tempo di ricarica all'80% da batterie com-  
 pletamente scariche ..... 2 h (indicativo)

#### POMPA IDRAULICA

Motore elettrico ..... 2 ad ingranaggi

#### CINGOLATURA

Tendicingolo ..... a grasso  
 Rulli per lato ..... 3 + slitta

Velocità di traslazione con 2<sup>a</sup> velocità Auto2speed:

- motore termico ..... 1,4 - 2,6 km/h  
 - motore lithium-ion ..... 0,4 - 0,8 - 1,6 km/h

PESO MACCHINA motore benzina ..... 1940 kg

PESO MACCHINA motore diesel ..... 1960 kg

PESO MACCHINA lithium-ion ..... 1992 kg

VELOCITÀ MAX VENTO ..... 12,5 m/s