

CM 300

Gru idraulica a montaggio rapido
Hydraulic crane with quick assembling
Grue hydraulique à montage rapide
Hydraulischer Schnellmontagekran
Grúa hidráulica de montaje rápido



EN 14439 C25

FEM 1.001-A3

PROGETTO e COSTRUZIONE / DESIGN and CONSTRUCTION:
LUIGI CATTANEO S.p.A

CM 300

 Nessun componente elettrico sul braccio e sulle parti alte della gru
No electrical component on the jib and the top of the crane

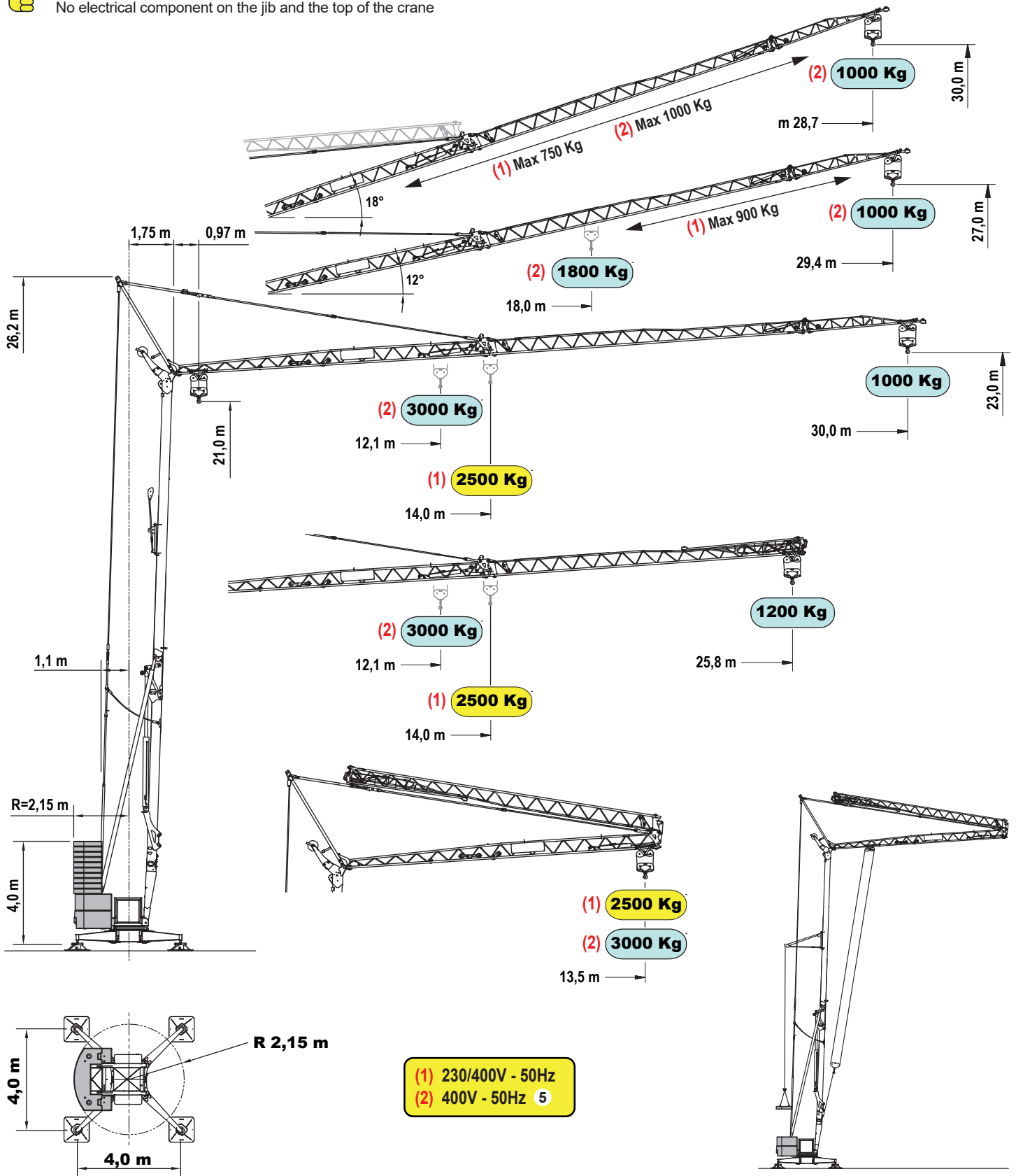

(1) 230/400V - 50Hz
(2) 400V - 50Hz 5

		(2)	(1)						⤴
Curve di carico	kg	3000	2500	2000	1800	1500	1200	1000	
Load diagrams	m	12.1	14.0	16.8	18.3	21.5	25.8	30.0	
Courbes de charge	m	12.1	14.0	16.8	18.3	21.5	25.8		
Lastkurven	m	12.1	14.0	16.8	18.3	21.5	25.8		
Curvas de cargas	m	13.5	13.5						

Prestazioni - Performances - Prestations - Leistungen - Prestaciones

Icona	kVA	230V - 50Hz (3 kW) 1 4,5 kW 2			230V - 50Hz (6 kW) 3 400V - 50Hz 10 kW 4						
		1°	2°	3°	1°	2°	3°				
inverter	7,5	↑	m/min.	5	18 (12)	26 (18)	↑	m/min.	5	16 (12)	40 (32)
			kg	2.500	1.000	600		kg	2.500	2.500	600
		↓	m/min.	5	18	40	↓	m/min.	5	18	40
			kg	2.500	2.500	1.000		kg	2.500	2.500	1.000
inverter	1,8	m/min. 20 - 35			m/min. 20 - 40						
inverter	2,2	g/min.			0,4 - 0,9						

Icona	kVA	400V - 50Hz 15 kW 5					
		1°	2°	3°	4°		
inverter	11	↑	m/min.	5	18	32	45
			kg	3.000	3.000	1.500	1.000
		↓	m/min.	5	18	32	45
			kg	3.000	3.000	1.000	1.000
inverter	3	m/min.		25 - 50			
inverter	2,2	g/min.		0,4 - 0,9			

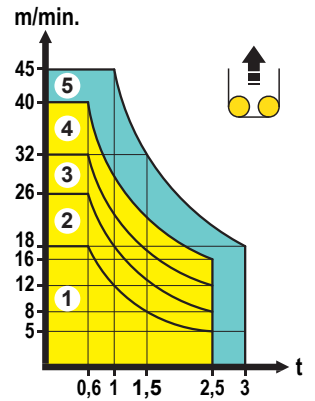

Montaggio - Erection - Montage - Montage - Montaje

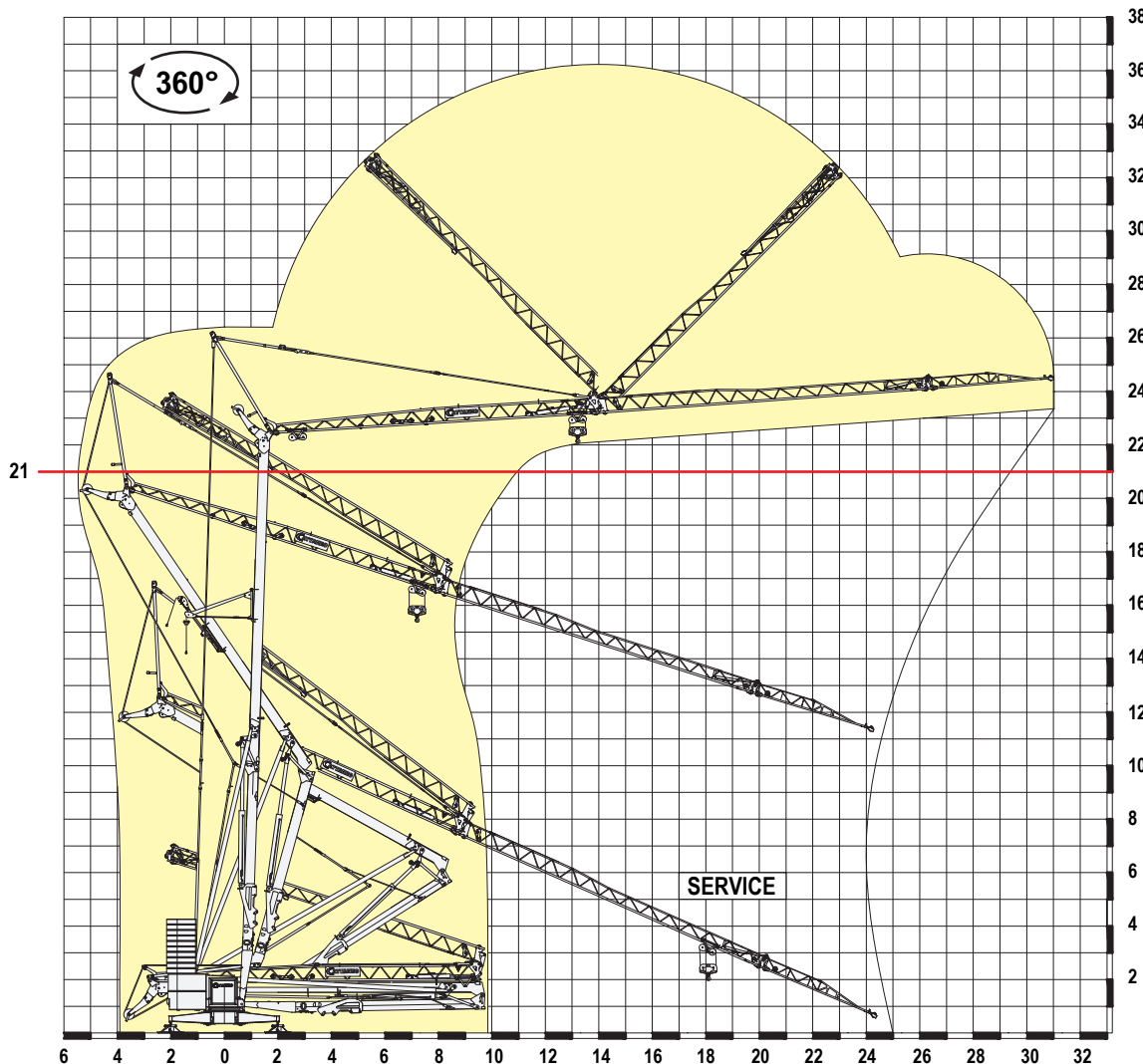

Contrappeso in lastre di cemento armato - Ferro-concrete ballast slabs Contrepoids en plaques de béton armé - Gegengewicht aus Betonplatten - Lastre en hormigón armado

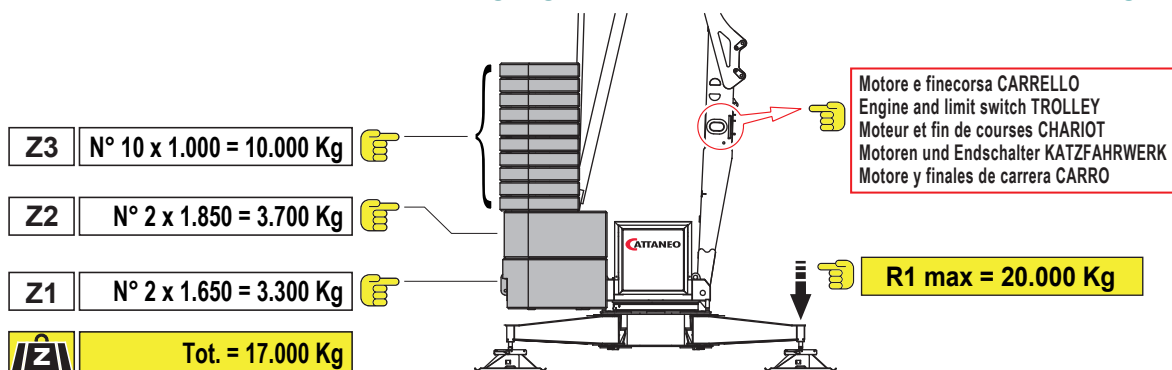

Trasporto - Transport - Transport - Transport - Transporte

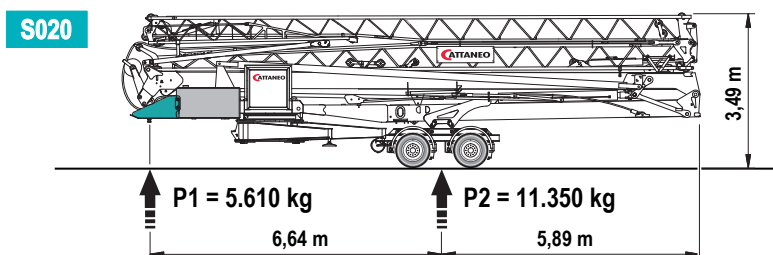
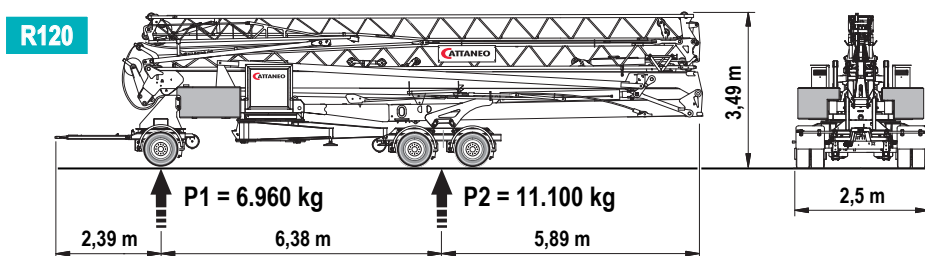
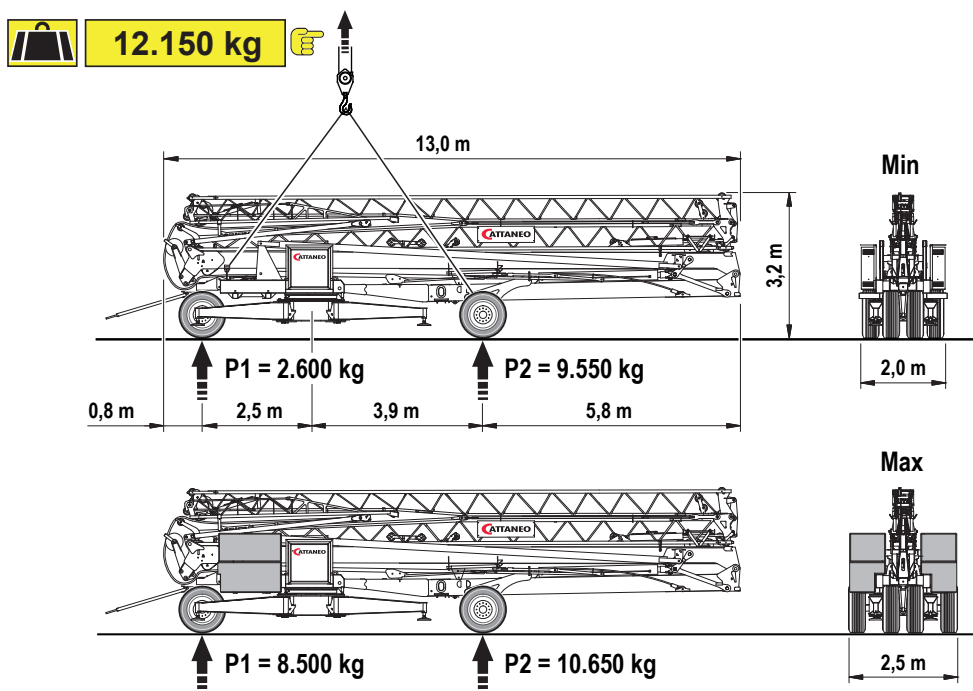

Otto	km/h	P1 kg	P2 kg
R120	80	6.960	11.100
S020	80	5.610	11.350

Dir. 2007/46/CE